

**Concept-Development
Practice Page** **35-2**

Compound Circuits

1. The initial circuit, below left, is a compound circuit made of a combination of resistors. It is reduced to a single equivalent resistance by the three steps, the circuits to its right, (a), (b), (c). In step (a), show the equivalent resistance of the parallel 4-Ω resistors. In step (b), combine this in series with the 3-Ω resistor. In step c, combine the last parallel pair to obtain the equivalent resistance of the circuit. (Note the similarity of this circuit and Figure 35.10 in your textbook.)

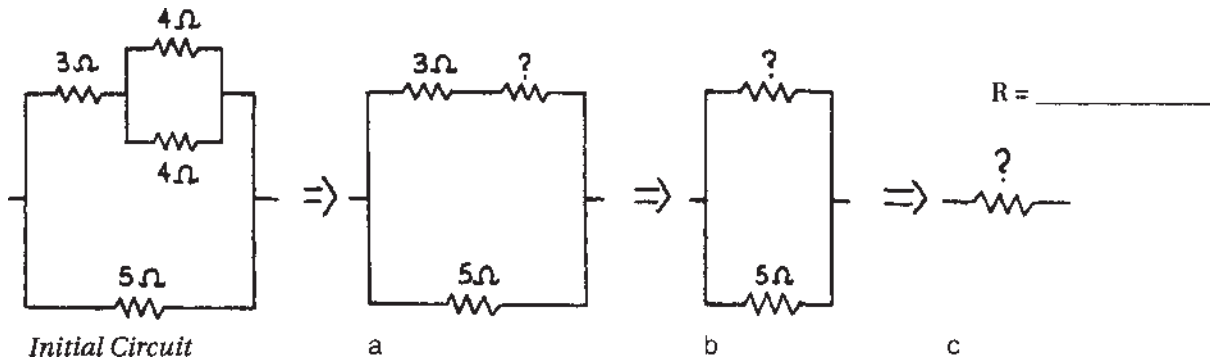

2. The circuit below is similar to Figure 35.11 in your textbook. In three successive steps, as in Question 1, replace each pair of resistors by a single resistor of equivalent resistance.



3. Find the equivalent resistance of these three circuits.

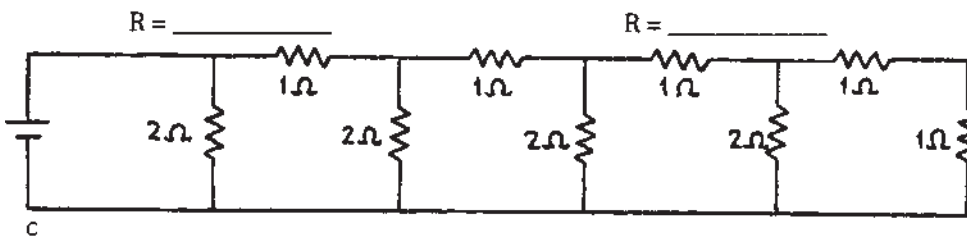
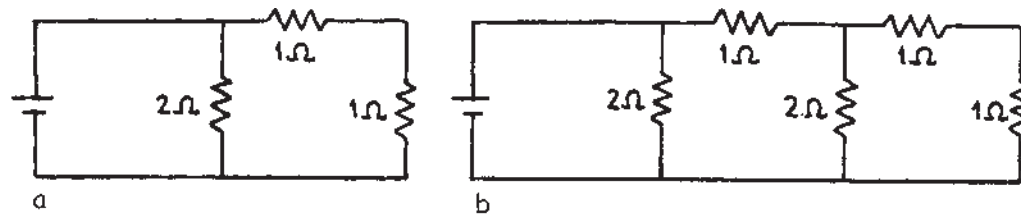

R = _____

4. The table beside circuit (a) below shows the current through each resistor, the voltage across each resistor, and the power dissipated as heat in each resistor. Find the similar correct values for circuits (b), (c), and (d), and put your answers in the tables shown.

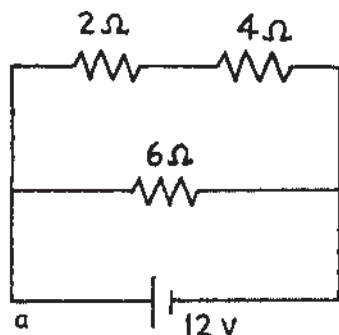

RESISTANCE	CURRENT	VOLTAGE	POWER
$2\ \Omega$	2 A	4 V	8 W
$4\ \Omega$	2 A	8 V	16 W
$6\ \Omega$	2 A	12 V	24 W

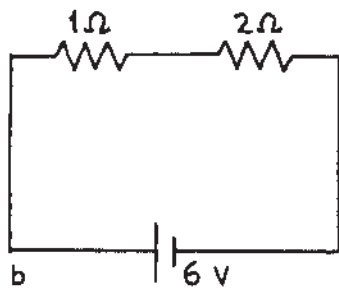

RESISTANCE	CURRENT	VOLTAGE	POWER
$1\ \Omega$			
$2\ \Omega$			

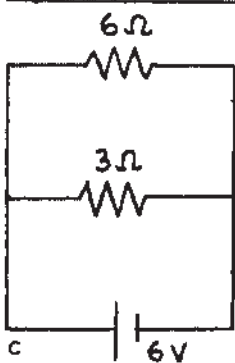

RESISTANCE	CURRENT	VOLTAGE	POWER
$6\ \Omega$			
$3\ \Omega$			

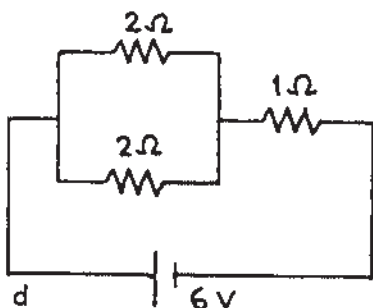

RESISTANCE	CURRENT	VOLTAGE	POWER
$2\ \Omega$			
$2\ \Omega$			
$1\ \Omega$			

CONCEPTUAL PHYSICS